



BERINGER
BICYCLE

MAIN FEATURES

BMX RACE CRANKSET

PRODUCT INFORMATION

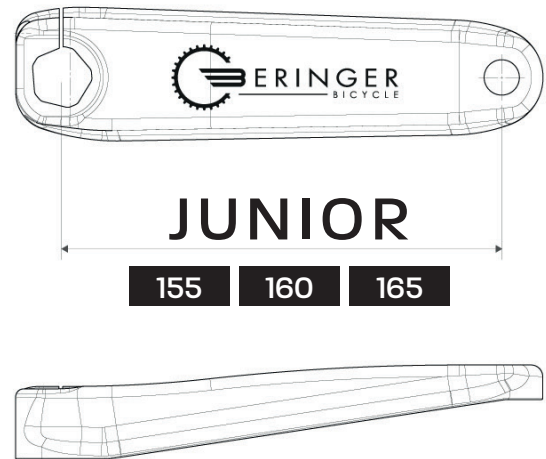
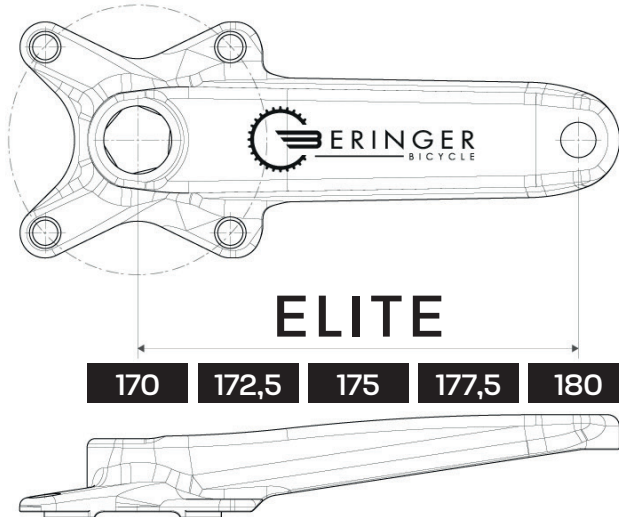

CrMo integrated steel shaft with 24 mm diameter and steel pedal notches

Weight: 720 gr (crank 175 mm)

CNC Machined Hollow Cranks in Forged Aluminum 6082 - Aerospace Technology

4 point spider cranks 104 BCD

Chainline from 42,5 mm to 43,5 mm (adjustment with rings)

Q-factor: 167 mm

Delivered without bearings

Large choice of anodizing color

orange, blue, red, green, purple, gold, titanium, silver.



MADE IN FRANCE

Beringer SAS
308 rue du Sou
69220 St Jean d'Ardières
FRANCE

contact@beringer-bicycle.com



beringer-bicycle.com

WARRANTY

All Beringer Bicycle products have a 1 year warranty from the date of purchase for manufacturing defaults. Proof of purchase will be requested. Any defective product must be returned to Beringer Bicycle. After contacting the Beringer team via our website, a return slip will be sent to you. It will have to be attached when sending the defective part back to us.

The warranty does not cover normal wear and tear of the product, improper use of the product, an accident, or any modification of the product.



BERINGER
BICYCLE

MAIN FEATURES

BMX RACE CRANKSET

Drive with hollow aluminium crank and 24 mm steel spindle.
104 mm chainwheel not provided



To clean the cranks, never use solvents or alcohol or pressurized cleaners. Use only clear water and soap.

THE COMPONENTS



Available sizes (mm)

ELITE	170	172,5	175	177,5	180
JUNIOR	155	160	165		

TOOLS

10 mm hex
5 mm hex
Torque wrench

Lubricating grease
Threadlock
Rubber mallet

Beringer SAS
308 rue du Sou
69220 St Jean d'Ardières
FRANCE

contact@beringer-bicycle.com



beringer-bicycle.com



1

TO CHECK BEFORE ASSEMBLING

Before mounting the crankset, you will have to make sure that you have a compatible bottom bracket installed on your BMX. **The inside diameter of the bottom bracket must be 24 mm, and the width must be 68 mm.**

2

ASSEMBLY OF THE CHAINRING

Make sure the contact surfaces are clean on the drive crank. Refer to the chainring manufacturer's instructions to position it, making sure its orientation is correct. Use the chimney bolts (not supplied) to help. Take care of the length of the chimney bolts to ensure a strong assembly of the chainring.
Recommended tightening torque: 10-12 N.m

3

ASSEMBLY OF THE DRIVE CRANK

Once the chainring is assembled on the crank spider, remove the adjusting bolt (if it is in place at the end of the spindle). Grease the spindle, add a small spacer if necessary, and slide it into the bottom bracket. This action requires little effort and should go easily. You can use a wooden or rubber mallet if you have some difficulty in getting the head out of the spindle on the other side of the case.
Do not use a steel hammer for this operation!

4

ASSEMBLY OF THE NON-DRIVE CRANKARM

Once the drive crankarm set up on your BMX, you can position the non drive crankarm on the pentagon of the spindle. If necessary install some spacers over the spindle on non-drive side. Be sure you push enough the crank to put it in contact with the bottom bracket. A space between the end of the spindle and the side of the crank should remain to make possible the preload of the subset.

5

MOUNTING OF THE BOLTS

Once the non drive crankarm is in place, you can add threadlock on the thread of the adjustment bolt and tighten it with a 10 mm hex. This tightening will preload the pedals on the bearing.
Recommended tightening torque: 10 N.m.
It is important to respect this maximum tightening torque in order not to prevent damage to the aluminum bolt and to cause premature bearing wear.

Add some threadlock on the two bolts CHC M6, then screw it in the crankarm and respect the **recommended tightening torque: 15 N.m.**

6

PEDAL INSTALLATION

Screw the pedals into the inserts respecting the **recommended tightening torque: 35 N.m.**

7

TEST IT ON YOUR FAVORITE TRACK

Go to your favorite BMX Race track to try your bike and beat your fastest times!